



# NATIONAL INSTITUTE OF TECHNOLOGY, DURGAPUR

MAHATMA GANDHI AVENUE

DURGAPUR –713 209, WEST BENGAL, INDIA

FAX: 0343-2574078; Website: www.nitdgp.ac.in; Telephones: + 91-9434788048

**BID REFERENCE:** NITD/CHEMICAL/Plan Grant/Furniture/2015-16/01

**Date:** 09.02.2016

To

\_\_\_\_\_  
\_\_\_\_\_

Dear Sir,

**SUB: Invitation for quotations for supply and installation of Furniture for writing and seating bench Under “Plan Grant 2015-2016”**

1. You are invited to submit your most competitive quotation for the listed items of **Furniture for writing and seating bench** as per **Annexure–II**. For each item, please quote separately in separate envelope superscripted with ITEM Name. Price bid form as per Annexure-I must be filled with complete numerical values. Please note that each item will include sub-items.
2. **Bid Price (Annexure-I)**
  - a) The contract shall be for the full quantity as described above. Corrections, if any, shall be made by crossing out, initialing, dating and re writing.
  - b) All duties, taxes and other levies payable by the contractor under the contract shall be included in the total price **F.O.R. NIT Durgapur**.
  - c) The rates quoted by the bidder shall be fixed for the duration of the contract and shall not be subject to adjustment on any account.
  - d) The bid price must be quoted in **Indian Rupees**.
3. **The bid submitted by the bidder must comprise the following:**
  - (a) Detailed technical specifications, conforming to the given specifications (vide Annexure – I), and literature /drawings /manuals of the goods/services are to supply.
  - (b) Authorized dealership certificate from the original manufacturer
  - (c) Credentials and list of organizations where the bidder supplied similar items
  - (d) Warranty period (2 year comprehensive on-site)
  - (e) Valid sales-tax / VAT clearance certificate
  - (f) Price bid as per Annexure-I
4. **Validity of Quotation**

Quotation shall remain valid for a period not less than 60 days after the deadline date specified for submission.
5. **Evaluation of Quotations**

The Purchaser will evaluate and compare the quotations determined to be substantially responsive i.e.

  - (a) which are properly signed and
  - (b) Conform to the terms and conditions, and specifications.

**6. Award of contract**

The Purchaser will award the contract to the bidder whose quotation has been determined to be substantially responsive, technologically acceptable and who has offered the lowest evaluated quotation price.

7.

7.1 Notwithstanding the above, the Purchaser reserves the right to accept or reject any quotations and to cancel the bidding process and reject all quotations at any time prior to the award of contract.

7.2 The bidder whose bid is accepted will be notified of the award of contract by the Purchaser prior to expiration of the quotation validity period. The terms of the accepted offer shall be incorporated in the purchase order.

8. Delivery shall be made at **Department of Chemical Engineering at NIT, Durgapur.**

9. Payment shall be made immediately within 30 days after satisfactory installation, commissioning and acceptance of the good.

10. Comprehensive onsite warranty shall be applicable to the supplied goods for a period of 24 **months** from the date of installation.

11. The Institute is **exempted from payment of custom and excise duty** on items mentioned below:

a) Scientific and technical instruments, apparatus, equipment (including computers)

b) Accessories, spare parts and consumables thereof

c) Computer software, CD-ROM, recorded magnetic tapes, microfilms, and microchips.

12. Settlement of any dispute will be made under the jurisdiction of Durgapur Court.

13. You are requested to provide your offer latest by 11.00 hours on February 19, 2016

14. The purchaser will open the bids at 11.30 hours on February 19, 2016 in the HOD office of Chemical Engg Department

15. The bid document must be signed and sealed and enclosed with the bid as a token of acceptance of all terms and conditions in the bid document by the bidder.

16. The items must be delivered within **30 days** from the date of placement of purchase order at the respective department.

17. Comprehensive onsite warranty for 24 **months** from the date of satisfactory installation shall be applicable for offered goods.

18. All other terms and conditions of GFR 2005 of the Government of India will be applicable.

19. **Place of Delivery: Dept. of Chemical Engineering, NIT Durgapur.**

20. **Installation / commissioning / demonstration requirement: Installation, commissioning, complete demonstration and successful running at Dept. of Chemical Engineering, NIT, Durgapur.**

21. **Total number of bench required: 25 sets (1 set = 1 High bench and 1 low bench). Actual quantities may vary according to the requirement.**

I look forward to receiving your quotations and thanking you,

**Head, Chemical Engineering Department**

**The bid must be addressed to:**

**Prof. A. K. Sadhukhan  
Professor & Head  
Department of Chemical Engineering  
NIT, Durgapur -713209, W.B.  
Telephones: + 91-9434788048**



### Specifications of Furniture for writing high bench and seating low bench

Sl no	Name of the Furniture	Specifications	Quantity
1	Furniture for writing high bench	<p><b><u>Fig. No. 1 Classroom Writing Bench High Bench:</u></b></p> <ol style="list-style-type: none"> <li>1. M. S square pipe 4.5 cm x 4.5 cm of 3 mm wall thickness.</li> <li>2. Spray paint (color bottle green).</li> <li>3. 1 mm Top sunmica (Wooden texture) (matte finish) pasted.</li> <li>4. Solid water proof ply board <math>\frac{3}{4}</math> inch (Branded company) four side wooden bit with polish matching color.</li> <li>5. Iron Leg cap.</li> </ol> <p>Top Size: 163 (excluding bit) cm x 30 cm (excluding bit) x 73 cm (excluding ply thickness)</p>	01
2.	Furniture for seating low bench	<p><b><u>Classroom Seating Low Bench:</u></b></p> <ol style="list-style-type: none"> <li>1. M. S square pipe 4.5 cm x 4.5 cm of 3 mm wall thickness.</li> <li>2. Spray paint (color bottle green).</li> <li>3. 1 mm Top sunmica (Wooden texture) (matte finish) pasted.</li> <li>4. Solid water proof ply board <math>\frac{3}{4}</math> inch (Branded company) four side wooden bit with polish matching color.</li> <li>5. Iron Leg cap.</li> </ol> <p>Top Size: 163 (excluding bit) cm x 30 cm (excluding bit) x 44 cm (excluding ply thickness)</p>	01

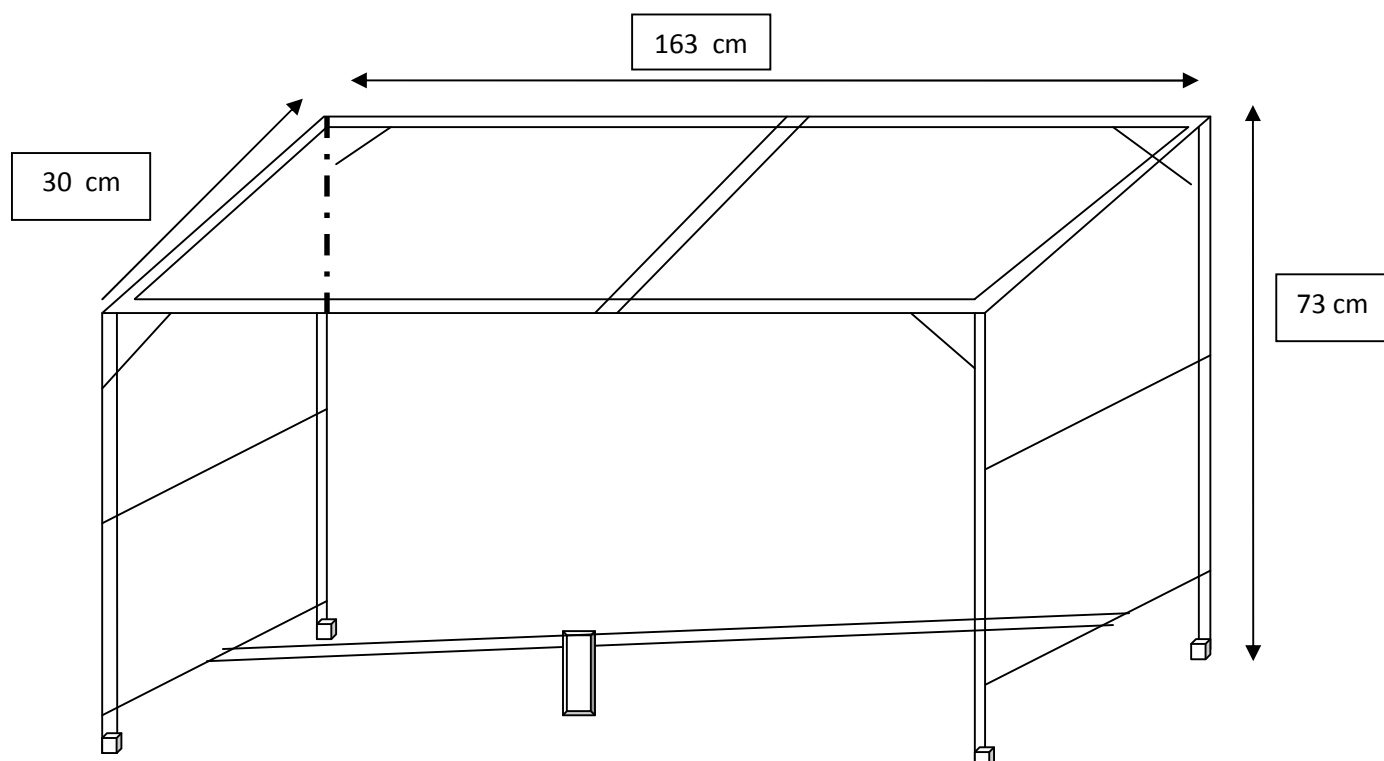

**Fig. No. 1**