

NITD/MM-RIG/AKM/Plasma/2020/3

NIT DURGAPUR

NOTICE INVITING TENDER (E-PROCUREMENT MODE)**NATIONAL INSTITUTE OF TECHNOLOGY, DURGAPUR**

MAHATMA GANDHI AVENUE

DURGAPUR –713 209, WEST BENGAL, INDIA

Department of Metallurgical and Materials Engineering

FAX: +91-343-2547375 E-mail: arup.mandal@mme.nitdgp.ac.in; Website: www.nitdgp.ac.in

Contact No.: +91-9434788110

NOTICE INVITING TENDER NO.: NITD/MM-RIG/AKM/Plasma/2020/3	Date: 14/09/2020
--	-------------------------

National Institute of Technology Durgapur is in the process of purchasing following item(s) as per details as given as under.

Items	To fabricate (i) Melting Chamber for transfer arc plasma generation (ii) Gas purification system at Department of Metallurgical & Materials Engineering, NIT Durgapur.
Earnest Money Deposit to be submitted	Rs. 5,000/- (E-Payment)
Installation and Commissioning	Required , Department of Metallurgical & Materials Engineering, NIT Durgapur.
Warranty	Onsite warranty of minimum 2 years from the date of delivery and installation at NIT Durgapur
Performance Security/ Performance Bank Guarantee (PBG)	The successful bidder must submit before release of payment a valid bank guarantee payable to “NIT Durgapur” on any nationalized bank amounting to 5 % of the order value towards Performance Security during the warranty period.
Calendar Completion/Delivery Period	Within 90 days from the date of issuing Purchase Order/Work Order/ Award of Contract.

Tender Documents may be downloaded from ITI e-Wizard Portal of MHRD <https://mhrd.euniwizarde.com> Aspiring Bidders who have not enrolled / registered in e-Wizard should enrol/ register before participating through the website <https://mhrd.euniwizarde.com>. Bidders are advised to go through instructions provided at ‘Instructions for online Bid Submission’.

Tenderers can access tender documents on the NIT DURGAPUR website (<https://nitdgp.ac.in>) Tenders@NITD.

(For searching in the ITI E-wizard site, kindly go to Department Select option and select ‘NIT DURGAPUR’. Thereafter, filling CAPTCHA and Click on “Search” button to view all NIT Durgapur tenders). Select the appropriate tender, fill them with all relevant information, and submit the completed tender document online on the website <https://mhrd.euniwizarde.com> as per the schedule given in the next page. No manual bids will be accepted. All quotation (both Technical and Financial should be submitted in the E-Wizard portal).

SCHEDULE

Name of Organization	National Institute of Technology
Tender Type (Open/Limited/EOI/Auction/Single)	Open
Tender Category (Services/Goods/works)	Goods
Type/Form of Contract (Work/Supply/Auction/Service/Buy/Empanelment/ Sell)	Buy
Product Category (Civil Works/Electrical Works/Fleet Management/Computer Systems/ Laboratory Equipments)	Laboratory Equipments
Source of Fund (Institute/Project)	RIG fund
Is Multi Currency Allowed	NO
Date of Issue/Publishing	14/09/2020
Document Download/Sale Start Date	14/09/2020
Bid submission start date	14/09/2020
Document Download/Sale End Date	24/09/2020 (17:00 Hrs)
Last Date and Time for Uploading of Bids	24/09/2020 (17:30 Hrs)
Date and Time of Opening of Technical Bids	25/09/2020 (10.00 Hrs.)
Tender Processing Fee	Rs. 885 /- (E-Payment)
EMD	5,000/- (E-Payment)
No. of Covers (1/2/3/4)	02
Bid Validity days (180/120/90/60/30)	90 days (From last date of opening of price bid)
Address for Communication	Dr. Arup Kumar Mandal Assistant Professor, Department of Metallurgical & Materials Engineering, National Institute of Technology Durgapur Durgapur – 713209, West Bengal, India
Contact No.	+91-9434788110
Email Address	arup.mandal@mme.nitdgp.ac.in
ITI Helpdesk Contact No. and mail address	Helpdesk Number – 011-4960 6060/06122520545 ewizardhelpdesk@gmail.com Mr SK Tariq- 9355030608 ewizardtariq@gmail.com Mr Siddharth Ghosh – 9355030604 ewizardsiddharth@gmail.com Mr Sanjeet Kumar Jha – 8882495599 ewizardsanjeet.kumar@gmail.com

PROCEDURE FOR SUBMISSION OF E-TENDER

The bidders are required to submit soft copies of their bid electronically on the ITI e-Wizard Portal using valid Digital Signature Certificates. Below mentioned instructions are meant to guide the bidders for registration on the e-Wizard Portal, prepare their bids in accordance with the requirements and submit their bids online on the ITI e-Wizard Portal. For more information, bidders may visit the ITI e-Wizard Portal <https://mhrd.euniwizarde.com>

1. REGISTRATION PROCESS ON ONLINE PORTAL

- a. Bidders to enroll on the e-Procurement module of the portal <https://mhrd.euniwizarde.com> by clicking on the link “Bidder Enrolment” as per portal norms.
- b. The bidders to choose a unique username and assign a password for their accounts. Bidders are advised to register their valid email address and mobile numbers as part of the registration process. These would be used for any communication from the e-Wizard Portal.
- c. Bidders must provide the details of PAN number, registration details etc as applicable and submit the related documents. The user id will be activated only after submission of complete details. The activation process will take minimum 24 working hours. After completion of registration payment, you can also send your acknowledgement copy on our help desk mail id **ewizardhelpdesk@gmail.com** for activation of your account.
- d. Bidders to register upon enrolment their valid Digital Signature Certificate (DSC: Class III Certificates with signing key and encryption usage) issued by any Certifying Authority recognized by CCA India with their profile.
- e. A bidder should register only one valid DSC. Please note that the bidders are responsible to ensure that they do not lend their DSCs to others, which may lead to misuse. Foreign bidders are advised to refer “DSC details for Foreign Bidders” for Digital Signature requirements on the portal.
- f. Bidder then logs in to the site through the secured login by entering their user ID/password and the password of the DSC / e-Token.

2. Tender Document Search

- a. Various built-in options are available in the e-Wizard Portal to facilitate bidders to search active tenders by several parameters. These parameters include Tender ID, organization, location, date, value, etc.
- b. There is also an option of advanced search for tenders, wherein the bidders may combine a number of search parameters such as organization name, a form of contract, location, date, other keywords, etc. to search for a tender published on the Online Portal.
- c. Once the bidders have selected the tenders they are interested in, they may download the required documents/tender schedules. These tenders can be moved to the respective ‘**Interested Tenders**’ folder. This would enable the Online Portal to intimate the bidders through SMS / e-mail in case there is any corrigendum issued to the tender document.
- d. The bidder should make a note of the unique Tender ID assigned to each tender, in case they want to obtain any clarification/help from the Helpdesk.

3. Bid Preparation

- a. Bidder should take into account any corrigendum published on the tender document before submitting their bids.
- b. Please go through the tender advertisement and the tender document carefully to understand the documents required to be submitted as part of the bid.
- c. Please note the number of covers in which the bid documents have to be submitted, the number of documents – including the names and content of each of the document that needs to be submitted. Any deviations from these may lead to rejection of the bid.
- d. Bidder, in advance, should get ready the bid documents to be submitted as indicated in the tender document/schedule and generally, they can be in PDF/XLS/PNG, etc. formats. Documents in PDF format with maximum Five (5) Mb file can be uploaded.

4. Bid Submission

- a. Bidder to log into the site well in advance for bid submission so that he/she uploads the bid in time i.e., on or before the bid submission time. Bidder will be responsible for any delay due to other issues.
- b. The bidder to digitally sign and upload the required bid documents one by one as indicated in the tender document.
- c. Bidders must pay required payments (Form fee, EMD, Tender Processing Fee etc) as mentioned before submitting the bid
- d. Bidder to select the payment option mode as specified in the Schedule (EMD/FORM FEE Section) to pay the form fee/ EMD wherever applicable and enter details of the instrument.
- e. A standard BoQ format has been provided with the tender document to be filled by all the bidders. Bidders to note that they should necessarily submit their financial bids in the prescribed format and no other format is acceptable.
- f. The server time (which is displayed on the bidders' dashboard) will be considered as the standard time for referencing the deadlines for submission of the bids by the bidders, the opening of bids, etc. The bidders should follow this time during bid submission.
- g. All the documents being submitted by the bidders would be encrypted using PKI encryption techniques to ensure the secrecy of the data, which cannot be viewed by unauthorized persons until the time of bid opening.
- h. The uploaded tender documents become readable only after the tender opening by the authorized bid openers.
- i. Upon the successful and timely submission of bids, the portal will give a successful bid submission message & a bid summary will be displayed with the bid no. and the date & time of submission of the bid with all other relevant details.
- j. Kindly have all relevant documents in a single PDF file.
- k. The off-line tender shall not be accepted and no request in this regard will be entertained whatsoever.

5. Amendment of bid document

At any time prior to the deadline for submission of proposals, the institutions reserve the right to add/ modify/ delete any portion of this document by the issuance of a Corrigendum, which would be published on the website and will also be made available to the all the Bidder who has been issued the tender document. The Corrigendum shall be binding on all bidders and will form part of the bid documents.

6. Instruction to Bidders

- a. Process for Bid submission through ITI Ewizard portal is explained in Bidder Manual. Bidders are requested to download Bidder Manual from the home page of website (<https://mhrd.euniwizarde.com>). Steps are as follows:
(Home page ⇒ Downloads ⇒ Bidder Manuals).
- b. The tenders will be received online through portal <https://mhrd.euniwizarde.com>. In the Technical Bids, the bidders are required to upload all the documents in .pdf format.
- c. Possession of Valid Class III Digital Signature Certificate (DSC) in the form of smart card/ e-Token in the company's name is a prerequisite for registration and participating in the bid submission activities through <https://mhrd.euniwizarde.com>. Digital Signature Certificates can be obtained from the authorized certifying agencies, details of which are available on the web site <https://mhrd.euniwizarde.com> under the link 'DSC help'.

Tenderers are advised to follow the instructions provided in the 'User Guide and FAQ' for the e-Submission of the bids online through the ITI e-Wizard Portal for e-Procurement at <https://mhrd.euniwizarde.com>

- d. The bidder has to **"Request the tender"** to portal before the **"Date for Request tender document"**, to participate in bid submission.
7. All entries in the tender should be entered in online Technical & Commercial Formats without any ambiguity.
8. Any order resulting from this e-tender shall be governed by the terms and conditions mentioned therein.
9. No deviation to the technical and commercial terms & conditions allowed.
10. The tender inviting authority has the right to cancel this e-tender or extend the due date of receipt of the bids

NATIONAL INSTITUTE OF TECHNOLOGY, DURGAPUR

MAHATMA GANDHI AVENUE
DURGAPUR –713 209, WEST BENGAL, INDIA

FAX: +91-343-2547375 E-mail: arup.mandal@mme.nitdgp.ac.in; Website: www.nitdgp.ac.in
Contact No.: +91-9434788110

NOTICE INVITING TENDER NO.: NITD/MM-RIG/AKM/Plasma/2020/3	Date: 14/09/2020
Sub: NOTICE INVING E-TENDER FOR “Supplying fabricated (i) Melting Chamber for transfer arc plasma generation (ii) Gas purification system at Department of Metallurgical & Materials Engineering, NIT Durgapur”.	

Invitation for Tender Offers

National Institute of Technology Durgapur invites online Bids (Technical bid and Commercial bid) from eligible and experienced furnace fabricator for supplying a fabricated laboratory scale (2 kg capacity) Transferred arc plasma generation unit , lined with refractory materials with the suitable gas purification system and temperature measurement system of liquid metal for performing melting and reduction experiments on site comprehensive warranty (for two years) from the date of installation of the material as per terms & conditions specified in the tender document, which is available on ITI e-procurement Portal <https://mhrd.euniwizarde.com>

TECHNICAL SPECIFICATIONS:

Name of the Equipment:

Sl. No.	Specification	Detailed Description
Melting Chamber for transfer arc plasma generation		
01	Electrode	<ul style="list-style-type: none"> • Diameter of the solid electrode 16 mm and 610 mm long • Hollow electrode having 4 mm bore diameter and 610 mm long drilled in the electrode for the flow of plasma gas
02	Electrode Holder	<ul style="list-style-type: none"> • The half portion of the electrode holder should be made of copper, and another half made of steel. • It should be attached on the top of the roof having a hand wheel to provide upward and downward electrode movement. • To protect the copper from the intense heat, provision of water circulation system for cooling the holder
03	Furnace Body and Roof	<ul style="list-style-type: none"> • Body should be made with Mild steel (MS) sheet of minimum 3-mm thickness • Shape of the body should be cylindrical shape having 300 mm diameter and 280 mm height. • The top of the furnace should be an arched shape swinging lid, made of 5-mm-thick steel plate • Provision of looking door/ charging door on the lid
04	High-Temperature Electrical Connector	<ul style="list-style-type: none"> • A graphite block of 120-mm diameter and 80-mm height should be provided for electrical connection to the charge through the bottom of the crucible

		<ul style="list-style-type: none"> Graphite block should be connected by a 250 mm long threaded stainless steel rod with the one point of electrical source by copper strip for electrical connection Around 20–25 steel nails (i.e., hard steel wire), of 3 mm diameter and 35 mm long to be fixed on the top of the graphite block embedded by refractory lining for making electrical connection between melt and graphite block
		<ul style="list-style-type: none">
05	Lining	<ul style="list-style-type: none"> Capacity of melting MS or SS is 2-5 kg Crucible diameter of about 80 mm and depth about 90 mm. Lining materials from the shell to centre of crucible in this order: Mica sheet insulation → Insulation bricks → Ramming mass Inner side of the Lid should be anchored with nails to hold ramming mass lining. Ramming mass should be Magnesite (basic), Fire clay (acidic) as per requirement For hardening purpose, sodium silicate gel to be applied
06	Temperature measurement system	<ul style="list-style-type: none"> Supply of a continuous temperature measurement system is needed. The provision of a continuous temperature measurement of liquid metal by a portable infrared spectrometer or online spectrometer to be fitted with this system is required.
Gas purification system		
01	Plasma gas flow control system	<ul style="list-style-type: none"> A gas purification train to be designed and fabricated with mixing and flow control system to pass desired plasma gas (nitrogen/ hydrogen) or their mixture. This system should permitted the dry gas flow in a range of 8×10^{-6} to 33×10^{-6} m³/s. The purification train provided mainly to remove moisture in all gasses and moisture plus oxygen in nitrogen as well as to control backfiring of hydrogen gas. Gas flow through purification train from cylinder: Blank bottle → CaCl₂ → Pyrogallol → CaCl₂ → Blank Bottle → Electrode Purification train should be provision of mixing two gases For the collection of molten samples during melting operation, a suction pipette made of silica tube with rubber suction bulb
Other terms and conditions		
OEM/vendor must certify availability of the spare for items quoted for at least 5 years from the date of purchase.		
Validity of quotation required: 90 days		
Warranty: The instrument should come with minimum 2 years onsite (24×7) warranty from the day of installation.		
Payment: 100 % Installation, commissioning, complete demonstration and successful running at Department of Metallurgical and Materials Engineering, NIT, Durgapur.		
Delivery Period: 90 days from the date of placement of purchase order		
Place of Delivery: Department of Metallurgical and Materials Engineering, NIT, Durgapur		
Installation and commissioning: Installation and commissioning at Department of Metallurgical and Materials Engineering, NIT, Durgapur		

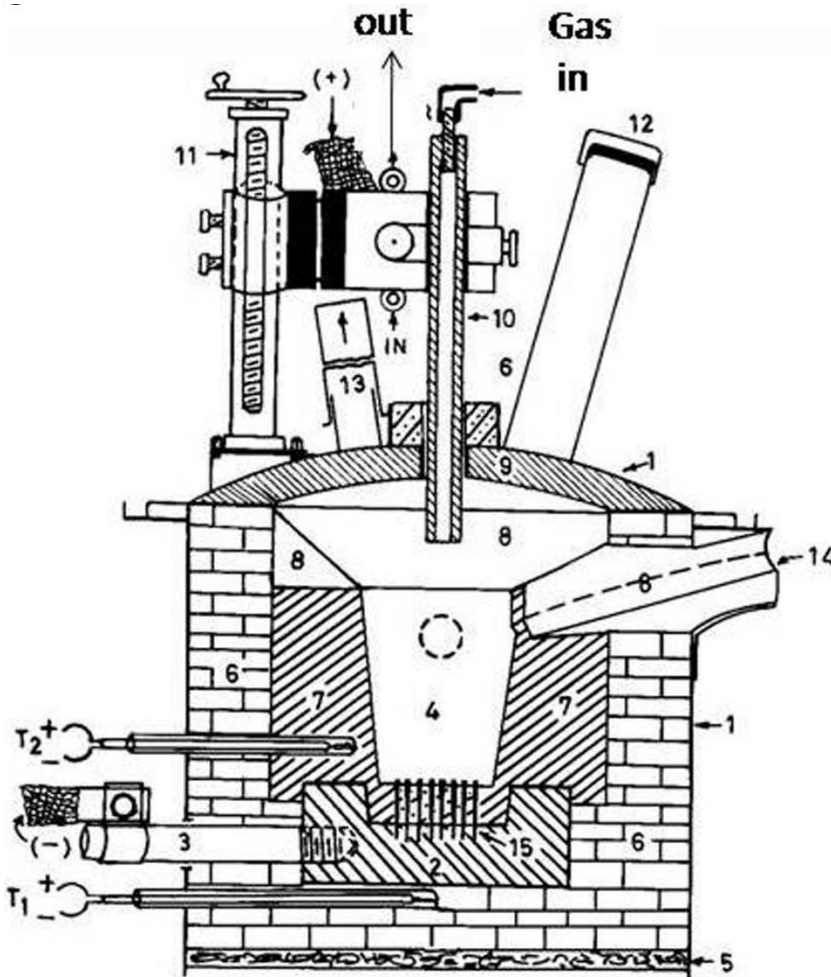

Legend

- 1. M.S. Plate
- 2. Graphite block
- 3. Stainless steel
Connecting rod
- 4. Magnesite
crucible
- 5. Asbestos sheet
- 6. Insulating bricks
- 7. Magnesite
- 8. Fire clay
- 9. Magnesite roof
- 10. Hallow graphite
electrode
- 11. Electrode holder
- 12. Peep window/
charging chute
- 13. Gas exit to dust
catcher
- 14. Spout
- 15. Steel wire
- T₁/T₂ Thermocouple

A complete set of tender documents may be downloaded by prospective bidder from the website <https://mhrd.euniwizarde.com>

Documents to be submitted in the Technical Folder:

1. Digitally signed copy of the filled in Notice Inviting Tender (NIT)
2. Detailed technical specifications and literature/ drawings/ manuals of the goods/products/ services have to be furnished,
3. Authorized dealership certificate from the original manufacturer, if applicable,
4. Scanned copy of EMD.
5. Warranty Period (2 years Comprehensive onsite (24×7))
6. Credentials and list of organizations with proof where the bidder supplied similar items.
7. List of other important documents (OID)

Sl. No.	Category	Sub Category	Sub Category Description
1	Certificate Details	GST Registration Certificate	GST Registration Certificate
		Partnership Deed (If applicable)	Partnership Deed
		Permanent Account Number	Permanent Account Number Details
		Power of Attorney (If applicable)	Power of Attorney
		Registration Certificate	Trade license certificate/shops & establishments certificate, PAN card, Certificate of incorporation (if applicable) etc. If trade license for FY (18-19) is not available till last date of submission, then self-attested stamped copy of renewal receipt from concerned municipality along with last FY (17-18) trade license is to be provided (both offline & online). This is provisional only.
2	Purchase Order Details	Purchase Orders	Purchase Orders
3	Work Details	Work Completed Certificate Copies	Work Completed Certificate Copies

Terms & Conditions Details

Sl. No.	Particulars / Specification
1	Due date: The tender has to be submitted on-line before the due date. The offers received after the due date and time will not be considered. No manual bids will be considered.
2	Preparation of Bids: The offer/bid should be submitted in two bid systems (i.e.) Technical bid and financial bid . The technical bid should consist of all technical details along with commercial terms and conditions. Financial bid should indicate item wise price for the items mentioned in the technical bid in the given format. The Technical bid and the financial bid should be submitted Online.
3	EMD (if applicable): The bidder should submit an EMD amount of Rs: 5,000/-as EMD amount Through E-Payment . The Technical Bid without EMD would be considered as UNRESPONSIVE and will not be accepted. The EMD will be refunded without any interest to the unsuccessful bidders after the award of contract. Earnest Money Deposit (EMD / Bid Security (BS) has to be submitted by bidders except those who are registered with National Small Industries Corporation (NSIC)/ Ministry of Micro Small Medium Enterprises or as per GFR 2017 guidelines. However, this certificate should be for manufacturing of the item indented and not for selling items manufactured by other firms. The certificate should be valid up to bid the bid validity
4	Refund of EMD: The EMD will be returned to unsuccessful bidders only after the tenders are finalized. In case of successful bidder, it will be retained till the successful and complete installation of the equipment.
5	Opening of the tender: The online bid will be opened by a committee duly constituted for this purpose. Online bids (complete in all respect) received along with EMD (if any) will be opened as mentioned at “Annexure: Schedule” in presence of representative each bidder if available. Only one representative of each bidder will be allowed to participate in the tender opening. Bid received without EMD (if present) will be rejected straight way. The technical bid will be opened online first and it will be examined by a technical committee (as per specification and requirement). The financial offer/bid will be opened only for the offer/bid which technically meets all requirements as per the specification. The bidders if interested may participate on the tender opening Date and Time. The bidder should produce authorization letter from their company to participate in the tender opening.
6	Acceptance/ Rejection of bids: The Committee reserves the right to reject any or all offers without assigning any reason.
7	Pre-qualification criteria: (i) Bidders should be the manufacturer / authorized dealer. Letter of Authorization from original equipment manufacturer (OEM) on the same and specific to the tender should be enclosed. (ii) An undertaking from the OEM is required stating that they would facilitate the bidder on a regular basis with technology/product updates and extend support for the warranty as well. (Ref. Annexure-II) (iii) OEM should be internationally reputed Branded Company. (iv) Non-compliance of tender terms, non-submission of required documents, lack of clarity of the specifications, contradiction between bidder specification and supporting documents etc. may lead to rejection of the bid. (v) In the tender, either the Indian agent on behalf of the Principal/OEM or Principal/OEM itself can bid but both cannot bid simultaneously for the same item/product in the same tender. (vi) If an agent submits bid on behalf of the Principal/OEM, the same agent shall not submit a bid on behalf of another Principal/OEM in the same tender for the same item/product.

8	<p>Performance Security/ Performance bank Guarantee (PBG): The supplier shall require to submit the performance security in the form of irrevocable bank guarantee issued by any Indian Nationalized Bank for an amount which is stated in the tender document, within 21 days from the date of receipt of the purchase order/LC and should be kept valid for a period of 60 days beyond the date of completion of warranty period or the same will be deducted from the bill/ invoice before payment is made. The same will be released on application by the supplier after the said interval (warranty period + 60 days).</p>
9	<p>Force Majeure: The Supplier shall not be liable for forfeiture of its performance security, liquidated damages or termination for default, if and to the extent that, it's delay in performance or other failure to perform its obligations under the Contract is the result of an event of Force Majeure.</p> <ul style="list-style-type: none"> • For purposes of this Clause, "Force Majeure" means an event beyond the control of the Supplier and not involving the Supplier's fault or negligence and not foreseeable. Such events may include, but are not limited to, acts of the Purchaser either in its sovereign or contractual capacity, wars or revolutions, fires, floods, epidemics, quarantine restrictions and freight embargoes. • If a Force Majeure situation arises, the Supplier shall promptly notify the Purchaser in writing of such conditions and the cause thereof. Unless otherwise directed by the Purchaser in writing, the Supplier shall continue to perform its obligations under the Contract as far as is reasonably practical, and shall seek all reasonable alternative means for performance not prevented by the Force Majeure event.
10	<p>Risk Purchase Clause: In event of failure of supply of the item/equipment within the stipulated delivery schedule, the purchaser has all the right to purchase the item/equipment from the other source on the total risk of the supplier under risk purchase clause.</p>
11	<p>Packing Instructions: Each package will be marked on three sides with proper paint/indelible ink, the following:</p> <ol style="list-style-type: none"> i. Item Nomenclature ii. Order/Contract No. iii. Country of Origin of Goods iv. Supplier's Name and Address v. Consignee details vi. Packing list reference number
12	<p>Delivery and Documents:</p> <p>Delivery of the goods should be made within a maximum of 90 days from the date of placement of official purchase order. Within 24 hours of shipment, the supplier shall notify the purchaser and the insurance company by cable/telex/fax/e mail the full details of the shipment including contract number, railway receipt number/ AAP etc. and date, description of goods, quantity, name of the consignee, invoice etc. The supplier shall mail the following documents to the purchaser with a copy to the insurance company:</p> <ol style="list-style-type: none"> 1. 4 Copies of the Supplier invoice showing contract number, goods' description, quantity, unit price, total amount; 3. Insurance Certificate if applicable; 4. Manufacturer's/Supplier's warranty certificate; 5. Inspection Certificate issued by the nominated inspection agency, if any 6. Supplier's factory inspection report; and 7. Certificate of Origin (if possible by the beneficiary); 8. Two copies of the packing list identifying the contents of each package. 9. The above documents should be received by the Purchaser before arrival of the Goods (except where the Goods have been delivered directly to the Consignee with all documents) and, if not received, the Supplier will be responsible for any consequent expenses
13	<p>Delayed delivery: If the delivery is not made within the due date for any reason, the Committee will have the right to impose penalty 1% per week and the maximum deduction is 10% of the contract value / price.</p>
14	<p>Prices:</p> <ol style="list-style-type: none"> a) The contract shall be for the full quantity as described above b) All duties, entry taxes, transport, insurance and other levies payable by the contractor under the contract shall be included in the total price F.O.R. NIT Durgapur.

	<p>c) The rates quoted by the bidder shall be fixed for the duration of the contract and shall not be subject to adjustments on any account.</p> <p>d) The Prices should be quoted in Indian Rupees only.</p> <p>e) The base price includes all type of prices except GST etc.</p>
15	<p>Notices: For the purpose of all notices, the following shall be the address of the Purchaser and Supplier.</p> <p>Purchaser Dr. Arup Kumar Mandal Assistant Professor, Department of Metallurgical & Materials Engineering National Institute of Technology, Durgapur – 713209</p> <p>Supplier:</p> <p>(All supplier's should submit its supplies information as per Annexure-II).</p>
16	<p>Progress of Supply: Wherever applicable, supplier shall regularly intimate progress of supply, in writing, to the Purchaser as under:</p> <ol style="list-style-type: none"> 1. Quantity offered for inspection and date; 2. Quantity accepted/rejected by inspecting agency and date; 3. Quantity dispatched/delivered to consignees and date; 4. Quantity where incidental services have been satisfactorily completed with date; 5. Quantity where rectification/repair/replacement effected/completed on receipt of any communication from consignee/Purchaser with date; 6. Date of completion of entire Contract including incidental services, if any; and 7. Date of receipt of entire payments under the Contract (In case of stage-wise inspection, details required may also be specified).
17	<p>Inspection and Tests: Inspection and tests prior to shipment of Goods and at final acceptance are as follows:</p> <ul style="list-style-type: none"> • After the goods are manufactured and assembled, inspection and testing of the goods shall be carried out at the supplier's plant by the supplier, prior to shipment to check whether the goods are in conformity with the technical specifications attached to the purchase order. Manufacturer's test certificate with data sheet shall be issued to this effect and submitted along with the delivery documents. The purchaser shall be present at the supplier's premises during such inspection and testing if need is felt. The location where the inspection is required to be conducted should be clearly indicated. The supplier shall inform the purchaser about the site preparation, if any, needed for installation of the goods at the purchaser's site at the time of submission of order acceptance. • The acceptance test will be conducted by the Purchaser, their consultant or other such person nominated by the Purchaser at its option after the equipment is installed at purchaser's site in the presence of supplier's representatives. The acceptance will involve trouble free operation and ascertaining conformity with the ordered specifications and quality. There shall not be any additional charges for carrying out acceptance test. No malfunction, partial or complete failure of any part of the equipment is expected to occur. The Supplier shall maintain necessary log in respect of the result of the test to establish to the entire satisfaction of the Purchaser, the successful completion of the test specified. • In the event of the ordered item failing to pass the acceptance test, a period not exceeding one weeks will be given to rectify the defects and clear the acceptance test, failing which the Purchaser reserve the right to get the equipment replaced by the Supplier at no extra cost to the Purchaser. • Successful conduct and conclusion of the acceptance test for the installed goods and equipment shall also be the responsibility and at the cost of the Supplier.
18	<p>Resolution of Disputes: The dispute resolution mechanism to be applied pursuant shall be as follows:</p> <ul style="list-style-type: none"> • In case of Dispute or difference arising between the Purchaser and a domestic supplier relating to any matter arising out of or connected with this agreement, such disputes or difference shall be settled in accordance with the Indian Arbitration & Conciliation Act, 1996. The dispute shall

	<p>be referred to the Director, National Institute of Technology Durgapur and if he is unable or unwilling to act, to the sole arbitration of some other person appointed by him and willing to act as such Arbitrator. The award of the said arbitrator so appointed shall be final, conclusive and binding on all parties to this order.</p> <ul style="list-style-type: none"> • In the case of a dispute between the purchaser and a Foreign Supplier, the dispute shall be settled by arbitration in accordance with provision of sub-clause above. But if this is not acceptable to the supplier then the dispute shall be settled in accordance with provisions of UNCITRAL (United Nations Commission on International Trade Law) Arbitration Rules. • The venue of the arbitration shall be the place from where the order is issued.
19	Applicable Law: Settlement of any dispute will be made under the jurisdiction of Durgapur Court.
20	<p>Right to Use Defective Goods</p> <p>If after delivery, acceptance and installation and within the guarantee and warranty period, the operation or use of the goods proves to be unsatisfactory, the Purchaser shall have the right to continue to operate or use such goods until rectifications of defects, errors or omissions by repair or by partial or complete replacement is made without interfering with the Purchaser's operation.</p>
21	<p>Supplier Integrity</p> <p>The Supplier is responsible for and obliged to conduct all contracted activities in accordance with the Contract using state of the art methods and economic principles and exercising all means available to achieve the performance specified in the contract.</p>
22	<p>Training</p> <p>The Supplier is required to provide training to the designated Purchaser's technical and end user personnel to enable them to effectively operate the equipment.</p>
23	<p>Installation & Demonstration</p> <p>Installation and demonstration of the equipment within one month of the arrival of materials at the NIT Durgapur will carried out at the site of installation.</p> <p>In case of any mis-happening/ damage to equipment and supplies during the carriage of supplies from the origin of equipment to the installation site, the supplier has to replace it with new equipment/supplies immediately at his own risk. Supplier will settle his claim with the insurance company as per his convenience. NIT Durgapur will not be liable to any type of losses in any form.</p>
24	<p>Insurance: For delivery of goods at the purchaser's premises, the insurance shall be obtained by the supplier in an amount equal to 110% of the value of the goods from "warehouse to warehouse" (final destinations) on "All Risks" basis including War Risks and Strikes. The insurance shall be valid for a period of not less than 3 months after installation and commissioning.</p>
25	<p>Incidental services: The incidental services also include: Furnishing of 01 set of detailed operations & maintenance manual.</p>
26	<p>Warranty:</p> <p>(i) Warranty period shall be from date of installation of Goods at the NIT Durgapur site of installation. The Supplier shall, in addition, comply with the performance and/or consumption guarantees specified under the contract. If for reasons attributable to the Supplier, these guarantees are not attained in whole or in part, the Supplier shall at its discretion make such changes, modifications, and/or additions to the Goods or any part thereof as may be necessary in order to attain the contractual guarantees specified in the Contract at its own cost and expense and to carry out further performance tests. The warranty should be comprehensive on site.</p> <p>(ii) The Purchaser shall promptly notify the Supplier in writing of any claims arising under this warranty. Upon receipt of such notice, the Supplier shall immediately within in 02 weeks arrange to repair or replace the defective goods or parts thereof free of cost at the ultimate destination. The Supplier shall take over the replaced parts/goods at the time of their replacement. No claim whatsoever shall lie on the Purchaser for the replaced parts/goods thereafter. The period for rectification of defects in the warranty period is 02 weeks. If the supplier having been notified fails to remedy the defects within 01 weeks, the purchaser may proceed to take such remedial action as may be necessary, at the supplier's risk and expenses and without prejudice to any other rights, which the purchaser may have against the supplier under the contract.</p> <p>(iii) The warranty period should be clearly mentioned. The maintenance charges (AMC) under different schemes after the expiry of the warranty may also be mentioned. The comprehensive onsite warranty will commence from the date of the satisfactory installation/commissioning of the</p>

	<p>equipment against the defect of any manufacturing, workmanship and poor quality of the components.</p> <p>(iv) After the warranty period is over, Annual Maintenance Contract (AMC)/Comprehensive Maintenance Contract (CMC) up to next two years should be started. The AMC/CMC charges will not be included in computing the total cost of the equipment.</p>
27	<p>Governing Language</p> <p>The contract shall be written in English language. English language version of the Contract shall govern its interpretation. All correspondence and other documents pertaining to the Contract, which are exchanged by the parties, shall be written in the same language.</p>
28	<p>Applicable Law (Sl. No. 18)</p> <p>The Contract shall be interpreted in accordance with the laws of the Union of India and all disputes shall be subject to place of jurisdiction.</p>
29	<p>Notices</p> <ul style="list-style-type: none"> • Any notice given by one party to the other pursuant to this contract/order shall be sent to the other party in writing or by cable, FAX or e mail and confirmed in writing to the other party's address. • A notice shall be effective when delivered or on the notice's effective date, whichever is later.
30	<p>Taxes</p> <p>Suppliers shall be entirely responsible for all taxes, duties, license fees, road permits, etc., incurred until delivery of the contracted Goods to the Purchaser. However, GST in respect of the transaction between the Purchaser and the Supplier shall be payable extra, if so stipulated in the order.</p>
31	<p>Duties</p> <p>NIT Durgapur is exempted from paying custom duty and necessary "Custom Duty Exemption Certificate" can be issued after providing following information and Custom Duty Exemption Certificate will be issued to the shipment in the name of the Institute, (no certificate will be issued to third party): The procured product should be used for teaching, scientific and research work only.</p> <p>a) Shipping details i.e. Master Airway Bill No. and House Airway No. (if exists)</p> <p>b) Forwarder details i.e. Name, Contact No., etc.</p> <p>NIT Durgapur is exempted from paying Excise Duty and necessary Excise Duty Exemption Certificate will be provided for which following information are required.</p> <p>b) Quotation with details of Basic Price, Rate, Tax & Amount on which ED is applicable</p> <p>c) Supply Order Copy</p> <p>d) Proforma-Invoice Copy.</p>
32	<p>Payment:</p> <p>100% payment shall be made by the Purchaser within 8 weeks after successful installation, commissioning and acceptance of the equipment at Department of Metallurgical and Materials Engineering, NIT Durgapur in good condition and to the entire satisfaction of the Purchaser and on production of unconditional performance bank guarantee (PBG) as specified in Clause 8 of tender terms and conditions.</p>
33	<p>User list: Brochure detailing technical specifications and performance, list of industrial and Educational establishments where the items enquired have been supplied must be provided. (Ref. Annexure-III)</p>
34	<p>Manuals</p> <p>(i) Before the goods and equipment are taken over by the Purchaser, the Supplier shall supply operation and maintenance manuals. These shall be in such details as will enable the Purchaser to operate, maintain, adjust and repair all parts of the works as stated in the specifications.</p> <p>(ii) The Manuals shall be in the ruling language (English) in such form and numbers as stated in the contract.</p> <p>(iii) Unless and otherwise agreed, the goods equipment shall not be considered to be completed for the purposes of taking over until such manuals and drawing have been supplied to the Purchaser.</p>
35	<p>Application Specialist: The bidder should mention in the Techno-Commercial bid the availability and names of Application Specialist and Service Engineers in the nearest regional office. (Ref. to Annexure-III)</p>
36	<p>Application Specialist: The bidder should mention in the Techno-Commercial bid the</p>

	availability and names of Application Specialist and Service Engineers in the nearest regional office. (Ref. to Annexure-III)
36	<p>Spare Parts The Supplier may be required to provide any or all of the following materials, notifications, and information pertaining to spare parts manufactured or distributed by the Supplier:</p> <ol style="list-style-type: none"> Such spare parts as the Purchaser may elect to purchase from the Supplier, providing that this election shall not relieve the Supplier of any warranty obligations under the Contract; and In the event of termination of production of the spare parts: Advance notification to the Purchaser of the pending termination, in sufficient time to permit the Purchaser to procure needed requirements; and Following such termination, furnishing at no cost to the Purchaser, the blueprints, drawings and specifications of the spare parts, if requested. <p><i>Supplier shall carry sufficient inventories to assure ex-stock supply of consumable spares for the Goods, such as graphide electrode, refractory bricks for lining, ramming mass, graphite blocks, SS nails, threaded SS rod for current discharge, graphite mould for pouring, sodium silicate gel for lining, safety goggles for melting, pyrogallol solution, CaCl₂ for gas purification train, rubber bellow fitted with silica tube for pin sampling etc. Other spare parts and components shall be supplied as promptly as possible but, in any case, within six months of placement of order.</i></p>
37	<p>Defective Equipment: If any of the equipment supplied by the bidder is found to be sub- standard, refurbished, un-merchantable or not in accordance with the description/specification or otherwise faulty, the committee will have the right to reject the equipment or its part. The prices of such equipment shall be refunded by the bidder with 18% interest if such payments for such equipment have already been made. All damaged or unapproved goods shall be returned at suppliers cost and risk and the incidental expenses incurred thereon shall be recovered from the supplier. Defective part in equipment, if found before installation and/or during warranty period, shall be replaced within 30 days on receipt of the intimation from this office at the cost and risk of supplier including all other charges. In case supplier fails to replace above item as per above terms & conditions, NIT Durgapur may consider “Banning” the supplier.</p>
38	<p>Termination for Default The Purchaser may, without prejudice to any other remedy for breach of contract, by written notice of default sent to the Supplier, terminate the Contract in whole or part:</p> <ol style="list-style-type: none"> If the Supplier fails to deliver any or all of the Goods within the period(s) specified in the order, or within any extension thereof granted by the Purchaser; or If the Supplier fails to perform any other obligation(s) under the Contract. If the Supplier, in the judgment of the Purchaser has engaged in corrupt or fraudulent practices in competing for or in executing the Contract. <p><input type="checkbox"/> For the purpose of this Clause:</p> <ol style="list-style-type: none"> “Corrupt practice” means the offering, giving, receiving or soliciting of anything of value to influence the action of a public official in the procurement process or in contract execution. “Fraudulent practice” means a misrepresentation of facts in order to influence a procurement process or the execution of a contract to the detriment of the Indenter, and includes collusive practice among Bidders (prior to or after bid submission) designed to establish bid prices at artificial non-competitive levels and to deprive the Indenter of the benefits of free and open competition;” <p><input type="checkbox"/> In the event the Purchaser terminates the Contract in whole or in part, the Purchaser may procure, upon such terms and in such manner, as it deems appropriate, Goods or Services similar to those undelivered, and the Supplier shall be liable to the Purchaser for any excess costs for such similar Goods or Services. However, the Supplier shall continue the performance of the Contract to the extent not terminated.</p>
39	<p>Disputes and Jurisdiction: Any legal disputes arising out of any breach of contract pertaining to this tender shall be settled in the court of competent jurisdiction located in Durgapur</p>
40	<p>Compliancy certificate: This certificate must be provided indicating conformity to the technical specifications. (Annexure-I)</p>
41	<p>All other terms and conditions of GFR 2017 of the Government of India will be applicable.</p>

Annexure I

Name of the Equipment:

Sl. No.	Specification	Detailed Description
Melting Chamber for transfer arc plasma generation		
01	Electrode	<ul style="list-style-type: none"> • Diameter of the solid electrode 16 mm and 610 mm long • Hollow electrode having 4 mm bore diameter and 610 mm long drilled in the electrode for the flow of plasma gas
02	Electrode Holder	<ul style="list-style-type: none"> • The half portion of the electrode holder should be made of copper, and another half made of steel. • It should be attached on the top of the roof having a hand wheel to provide upward and downward electrode movement. • To protect the copper from the intense heat, provision of water circulation system for cooling the holder
03	Furnace Body and Roof	<ul style="list-style-type: none"> • Body should be made with Mild steel (MS) sheet of minimum 3-mm thickness • Shape of the body should be cylindrical shape having 300 mm diameter and 280 mm height. • The top of the furnace should be an arched shape swinging lid, made of 5-mm-thick steel plate • Provision of looking door/ charging door on the lid
04	High-Temperature Electrical Connector	<ul style="list-style-type: none"> • A graphite block of 120-mm diameter and 80-mm height should be provided for electrical connection to the charge through the bottom of the crucible • Graphite block should be connected by a 250 mm long threaded stainless steel rod with the one point of electrical source by copper strip for electrical connection • Around 20–25 steel nails (i.e., hard steel wire), of 3 mm diameter and 35 mm long to be fixed on the top of the graphite block embedded by refractory lining for making electrical connection between melt and graphite block
05	Lining	<ul style="list-style-type: none"> • Capacity of melting MS or SS is 2-5 kg • Crucible diameter of about 80 mm and depth about 90 mm. • Lining materials from the shell to centre of crucible in this order: Mica sheet insulation → Insulation bricks → Ramming mass • Inner side of the Lid should be anchored with nails to hold ramming mass lining. • Ramming mass should be Magnesite (basic), Fire clay (acidic) as per requirement • For hardening purpose, sodium silicate gel to be applied
06	Temperature measurement system	<ul style="list-style-type: none"> • Supply of a continuous temperature measurement system is needed. • The provision of a continuous temperature measurement of liquid metal by a portable infrared spectrometer or online spectrometer to be fitted with this system is required.
Gas purification system		

01	Plasma gas flow control system	<ul style="list-style-type: none"> • A gas purification train to be designed and fabricated with mixing and flow control system to pass desired plasma gas (nitrogen/ hydrogen) or their mixture. • This system should permitted the dry gas flow in a range of 8×10^{-6} to 33×10^{-6} m³/s. • The purification train provided mainly to remove moisture in all gasses and moisture plus oxygen in nitrogen as well as to control backfiring of hydrogen gas. • Gas flow through purification train from cylinder: Blank bottle → CaCl₂ → Pyrogallol → CaCl₂ → Blank Bottle → Electrode • Purification train should be provision of mixing two gases • For the collection of molten samples during melting operation, a suction pipette made of silica tube with rubber suction bulb
Other terms and conditions		
OEM/vendor must certify availability of the spare for items quoted for at least 5 years from the date of purchase.		
Validity of quotation required: 90 days		
Warranty: The instrument should come with minimum 2 years onsite (24×7) warranty from the day of installation.		
Payment: 100 % Installation, commissioning, complete demonstration and successful running at Department of Metallurgical and Materials Engineering, NIT, Durgapur.		
Delivery Period: 90 days from the date of placement of purchase order		
Place of Delivery: Department of Metallurgical and Materials Engineering, NIT, Durgapur		
Installation and commissioning: Installation and commissioning at Department of Metallurgical and Materials Engineering, NIT, Durgapur		

I have also enclosed all relevant documents in support of my claims, (as above) in the following pages.

Signature of Bidder with date

Name:

Designation:

Organization Name:

Contact No. :

E-mail Id:

ANNEXURE-II

<<Organization Letter Head>>

DECLARATION SHEET

We/I, _____ hereby certify that all the information and data furnished by our organization with regard to this tender specification are true and complete to the best of our knowledge. I have gone through the specification, conditions and stipulations in details and agree to comply with the requirements and intent of specification.

This is certified that our organization has been authorized (Copy attached) by the OEM to participate in Tender. We further certified that our organization meets all the conditions of eligibility criteria laid down in this tender document. Moreover, OEM has agreed to support on regular basis with technology / product updates and extend support for the warranty.

The prices quoted in the financial bids are subsidized due to academic discount given to NIT Durgapur.

We, further specifically certify that our organization has not been Black Listed/De Listed or put to any Holiday by any Institutional Agency/ Govt. Department/ Public Sector Undertaking in the last three years.	NAME & ADDRESS OF THE Vendor/ Manufacturer / Agent
Phone No.:	
Fax	
E-mail	
Contact Person Name	
Mobile Number	
TIN Number	
PAN Number	
(In case of on-line payment of EMD) RTGS/NEFT challan No (For EMD) with date:	

(Signature of the Tenderer with date)

Name:

Seal of the Company

ANNEXURE-III

LIST OF GOVT. ORGANIZATION/DEPTT

List of Government Organizations for whom the Bidder has undertaken such work during last two years (must be supported with work orders)			
Sl. No.	Name of the organization with address	Name of Contact Person	Contact No.

Name of application specialist / Service Engineer who have the technical competency to handle and support the quoted product during the warranty period.			
Sl. No.	Name of the organization with address	Name of Contact Person	Contact No.

Signature of Bidder with date

Name:

Designation:

Organization Name:

Contact No. :

E-mail Id:

SUBMISSION OF BID

The Online bids (complete in all respect) must be uploaded online in **two** Envelops as explained below:

Envelope – 1 (Following documents to be provided as single PDF file)			
Sl. No.	Documents	Content	File Types
1	TECHNICAL BID	Compliance Sheet as per Annexure – I	.PDF
2		Organization Declaration Sheet as per Annexure – II	.PDF
3		List of organizations/ clients where the same products have been supplied (in last two years) along with their Contact number(s). (Annexure-III)	.PDF
4		Technical supporting documents in support of all claims	.PDF
Envelope – 2			
Sl. No.	TYPES	Content	File Types
1	Financial Bid	Price bid should be submitted in .xls format	. xls